

- Design:** ASME B16.34 & API-600 or BS-1414
- Sizes:** 2" - 48" (other sizes under request)
- ANSI Class:** 600 - 4500
- Face to Face:** ASME B16.10
- Flanged Ends:** From 2" to 24" as per ASME B16.5; above 24" as per ASME B16.47 or MSS-SP-44. Others upon request
- Butt Weld Ends:** ASME B16.25
- Test:** ASME B16.34, API 598, BS EN 12266-2 (BS 6755), ISO 5208. Others under request
- Construction:**
- O.S & Y. Rising Stem
 - One Wedge with parallel discs with parallel seat rings
 - Threaded, Welded or integral Seat Ring
 - Metal Seats
 - Pressure seal desing with clamp, easy to disassemble
 - Manual and actuator operated (electric, pneumatic, hydraulic...)
- Accessories:** Bypass, overpressure protection device, handwheel with chain, balance hole, lantern ring, belows seal, limit micro switches, spring loading packing
- Materials:** A216-WCB / WCC, A352-LCB, A217-WC6, A217-WC9, A217-C5, A217-C12, A217-C12A, A351-CF8, 351-CF3, A351-CF8M, A351-CF3M, A351-CF8C, Alloy 20, Duplex, Super Duplex, Incoloy, Monel, Inconel, Titanium
- Trim:** F6, 304, 310, Hard 410, 410 Full Hard faced, 410 and Ni-Cu, 410 and Hard faced, Monel, 316, Monel and Hard faced, 316 and Hard faced, Alloy 20, Alloy 20 & Hard faced, 304 Full Hard faced, 316 Full Hard faced, 347 Full Hard faced, Alloy 20 Full Hard faced, Alloy 625

Other trim and materials under request

Babcock Figure

ANSI 600 lbs	All sizes	ANSI 2500 lbs	All sizes
89806 Raised face	RF ends	89825 Raised face	RF ends
89706 Butt weld	BW ends	89725 Butt weld	BW ends
ANSI 900 lbs	All sizes	ANSI 4500 lbs	All sizes
89809 Raised face	RF ends	89845 Raised face	RF ends
89709 Butt weld	BW ends	89745 Butt weld	BW ends
ANSI 1500 lbs	All sizes		
89815 Raised face	RF ends		
89715 Butt weld	BW ends		

REF. CODE 86

Follower eye for very laminar flow is available on request. It avoids any trubulences an d minimizes the pressure drop.

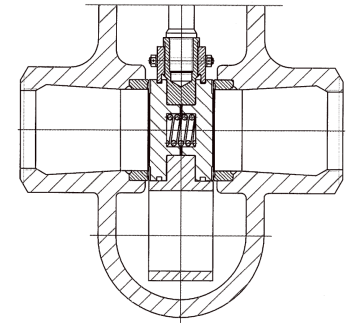

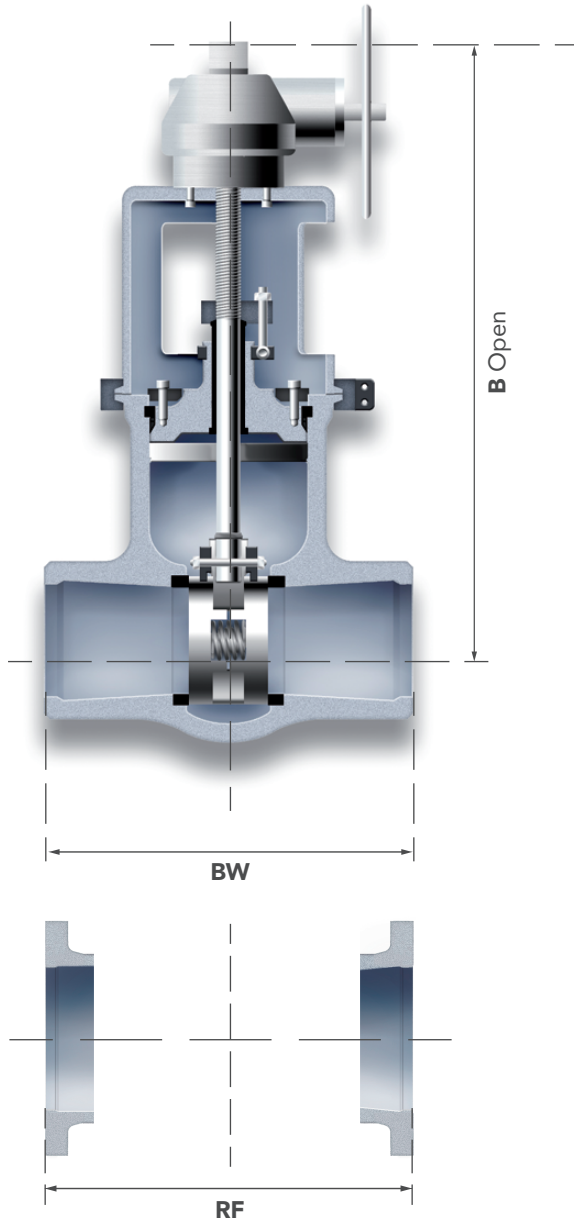

dimensions & weights chart

asme class		900											
		2 1/2"	3"	4"	6"	8"	10"	12"	14"	16"	18"	20"	24"
1500	SIZE	2 1/2"	3"	4"	6"	8"	10"	12"	14"	16"	18"	20"	24"
	RF	419.1	469.9	546.1	704.8	831.8	990.6	1130.3	1257.3	1384.3	1536.7	1663.7	1943.1
	BW	254	304.8	406.4	558.8	711.2	863.6	990.6	1066.8	1193.8	1346.2	1473.2	1943.1
	A	675	700	900	1134	1293	1510	1530	2230	2238	2250	2320	-
	B	356	381	457	610*	686*	762*	762*	762*	915*	915*	915*	915*
	WEIGHT (BW)	85	87	191	382	641	1113	1495	2396	2841	4346	5247	8353
2500	SIZE	2 1/2"	3"	4"	6"	8"	10"	12"	14"	16"	18"	20"	24"
	RF	508	577.8	673.1	914.4	1022.3	1270	1422.4	-	-	-	-	-
	BW	330.2	368.3	457.2	609.6	762	614.4	1041.4	1117.6	1244.6	1397	1397	-
	A	818	835	960	981	1330	1405	1682	2106	2200	2300	2445	-
	B	457	457	534	610*	762*	762*	762*	915*	915*	915*	915*	-
	WEIGHT (BW)	159	167	254	477	795	1558	2459	3138	3795	5056	6487	9540

All dimensions are shown in millimeters and weights in Kg. (weights for BW)
 Gear actuator is recommended for: ASME Class 600/900/1500: ≥10"
 ASME Class 2500: ≥6"