

- Design:** ASME B16.34 & API-600 or BS-1414
- Sizes:** 1/2" - 72" (other sizes under request)
- ANSI Class:** 150 - 2500
- Face to Face:** ASME B16.10
- Flanged Ends:** From 2" to 24" as per ASME B16.5; above 24" as per ASME B16.47 or MSS-SP-44. Others upon request
- Butt Weld Ends:** ASME B16.25
- Test:** ASME B16.34, API 598, BS EN 12266-2 (BS 6755), ISO 5208. Others under request
- Construction:**
- O.S & Y. Rising Stem
 - Flexible or Solid wedge. Double Disc (see code 82) and Parallel Slide designs (see code 87) also available
 - Threaded, Welded or integral Seat Ring
 - Metal Seats
 - Bolted Bonnet
 - Manual and actuator operated (electric, pneumatic, hydraulic...)
- Accessories:** Bypass, overpressure protection device, handwheel with chain, balance hole, lantern ring, below seal, limit micro switches, spring loading packing
- Materials:** A216-WCB / WCC, A352-LCB, A217-WC6, A217-WC9, A217-C5, A217-C12, A217-C12A, A351-CF8, A351-CF3, A351-CF8M, A351-CF3M, A351-CF8C, Alloy 20, Duplex, Super Duplex, Incoloy, Monel, Inconel, Titanium
- Trim:** F6, 304, 310, Hard 410, 410 Full Hard faced, 410 and Ni-Cu, 410 and Hard faced, Monel, 316, Monel and Hard faced, 316 and Hard faced, Alloy 20, Alloy 20 & Hard faced, 304 Full Hard faced, 316 Full Hard faced, 347 Full Hard faced, Alloy 20 Full Hard faced, Alloy 625

Other trim and materials under request

Babcock Figure

ANSI 150 lbs
22801 Raised face
22701 Butt weld

All sizes
RF ends
BW ends

ANSI 900 lbs
22809 Raised face
22709 Butt weld

All sizes
RF ends
BW ends

ANSI 300 lbs
22803 Raised face
22703 Butt weld

All sizes
RF ends
BW ends

ANSI 1500 lbs
22815 Raised face
22715 Butt weld

All sizes
RF ends
BW ends

ANSI 600 lbs
22806 Raised face
22706 Butt weld

All sizes
RF ends
BW ends

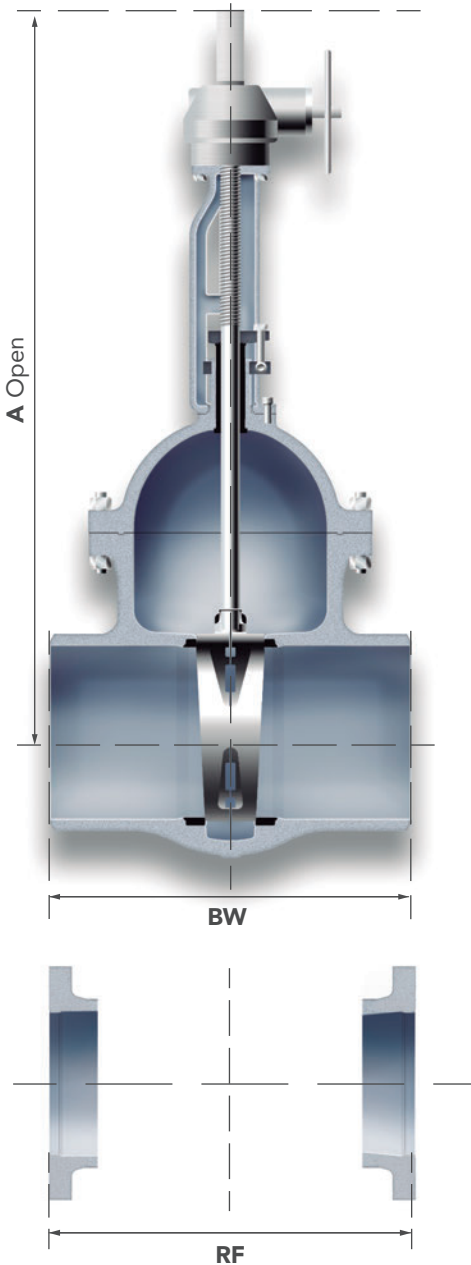

dimensions & weights chart

asme class	SIZE																				
		2"	2½"	3"	4"	6"	8"	10"	12"	14"	16"	18"	20"	24"	26"	28"	30"	32"	34"	36"	42"
150	RF	177.8	190.5	203.2	228.6	266.7	292.1	330.5	355.6	381	406.4	431.8	457.2	508	588.8	609.6	609.6	711.2	711.2	711.2	787.4
	BW	215.9	241.3	282.6	304.8	403.2	419.1	457.2	501.6	571.5	609.6	660.4	711.2	812.8	863.6	914.4	914.4	965.2	1016	1016	
	A	381	450	473	586	835	1025	1240	1410	1570	1700	2070	2290	2490	2700	3120	3380	3410	3540	3800	4320
	B	204	204	229	254	305	381	457	BG	BG	BG	BG	BG	BG	BG	BG	BG	BG	BG	BG	BG
	WEIGHT (BW)	14	23	26	43	74	113	199	291	347	503	572	717	1126	-	1761	2024	2276	-	3076	-
	WEIGHT (RF)	17	27	33	50	82	133	217	320	384	550	657	807	1246	-	1927	2376	2486	-	3596	5096
300	SIZE	2"	2½"	3"	4"	6"	8"	10"	12"	14"	16"	18"	20"	24"	30"	36"					
	RF-BW	215.9	241.3	282.6	304.8	403.2	419.1	457.2	501.6	762	838.2	914.4	990.6	1143	1397	1727.2					
	A	400	450	542	619	853	1085	1300	1476	1600	1970	2066	2250	2900	3540	3800					
	B	204	204	229	254	381	457	533	BG	BG	BG	BG	BG	BG	BG	BG					
	WEIGHT (BW)	23	31	44	65	115	192	268	429	592	845	1021	1456	2291	3776	5896					
	WEIGHT (RF)	27	36	52	80	134	237	330	533	666	1007	1201	1716	2796	4306	6628					
600	SIZE	2"	2½"	3"	4"	6"	8"	10"	12"	14"	16"	18"	20"	24"	30"						
	RF	292.1	330.2	355.6	431.8	558.8	660.4	787.4	838.2	889	990.6	1092.2	1193.8	1397	1651						
	BW	292.1	-	355.6	431.8	558.8	660.4	787.4	-	-	-	-	-	-	-						
	A	400	510	539	744	979	1210	1560	1600	1750	1932	2350	2400	3100	3450						
	B	204	254	254	355	533	610	610	BG	BG	BG	BG	BG	BG	BG						
	WEIGHT (BW)	32	47	65	101	205	325	493	634	1116	1444	1824	2198	3356	6156						
WEIGHT (RF)	38	55	85	128	250	410	620	781	1284	1816	2146	2536	4076	6696							
900	SIZE	2"	2½"	3"	4"	6"	8"	10"	12"	14"	16"	18"	20"	24"							
	RF	368.3	419.1	381	457.2	606.6	736.6	838.2	965.2	1028.7	1130.3	1219.2	1320.8	1549.4							
	BW	215.9	254	304.8	355.6	508	660.4	787.4	914.4	990.6	1092.2	1219.2	1320.8	1549.4							
	A	605	605	615	760	980	1250	1400	1722	1980	2020	2160	2280	-							
	B	305	355	355	381	457	BG	BG	BG	BG	BG	BG	BG	BG							
	WEIGHT (BW)	56	68	73	115	254	488	800	1210	1700	2200	3000	3800	-							
WEIGHT (RF)	79	90	105	119	356	563	977	1446	1996	2450	3300	4200	-								
1500	SIZE	2"	2½"	3"	4"	6"	8"	10"	12"	14"	16"	18"	20"	24"							
	RF	368.3	419.1	469.9	546.1	704.8	831.8	990.6	1130.3	1257.3	1348.3	1536.7	1663.7	1943.1							
	BW	215.9	254	304.8	406.4	558.8	711.2	863.6	990.6	1066.8	1193.8	1346.2	1473.2	1943.1							
	A	610	610	750	840	1010	1230	1480	1612	1765	1930	2160	2320	2640							
	B	355	355	457	610	BG	BG	BG	BG	BG	BG	BG	BG	BG							
	WEIGHT (BW)	91	141	182	282	581	975	1986	2846	3316	4886	-	-	-							
WEIGHT (RF)	114	172	237	334	677	1224	2274	3256	4096	5956	-	-	-								

All dimensions are shown in millimeters and weights in Kg.

B: Handwheel diameter.

BG: Gear actuator is recommended.