

- Design:** ASME B16.34 , BS-1873
- Sizes:** 2" - 24" (other sizes under request)
- ANSI Class:** 600 - 4500
- Face to Face:** ASME B16.10
- Flanged Ends:** From 2" to 24" as per ASME B16.5; above 24" as per ASME B16.47 or MSS-SP-44. Others upon request
- Butt Weld Ends:** ASME B16.25
- Test:** ASME B16.34, API 598, BS EN 12266-2 (BS 6755), ISO 5208. Others under request
- Construction / Features:**
- Plug disc. Needle /Parabolic / Ball type disc also available (see code 16)
 - Low pressure drop
 - Excellent resistance to thermal changes
 - Quick and easy repair in the line
 - Seat integrally stellite
 - Disc fully guided
 - Renewable disc guide bushing,
 - Drop-tight shut-off
 - Pressure seal design with clamp, easy to disassemble.
- Accessories:** Bypass, overpressure protection device, handwheel with chain, balance hole, lantern ring, belows seal, limit micro switches, spring loading packing
- Materials:** A216-WCB / WCC, A352-LCB, A217-WC6, A217-WC9, A217-C5, A217-C12, A217-C12A, A351-CF8, A351-CF3, A351-CF8M, A351-CF3M, A351-CF8C, Alloy 20, Duplex, Super Duplex, Incoloy, Monel, Inconel, Titanium
- Trim:** F6, 304, 310, Hard 410, 410 Full Hard faced, 410 and Ni-Cu, 410 and Hard faced, Monel, 316, Monel and Hard faced, 316 and Hard faced, Alloy 20, Alloy 20 & Hard faced, 304 Full Hard faced, 316 Full Hard faced, 347 Full Hard faced, Alloy 20 Full Hard faced, Alloy 625

Other trim and materials under request

Babcock Figure

ANSI 600 lbs	All sizes	ANSI 2500 lbs	All sizes
75806 Raised face	RF ends	75825 Raised face	RF ends
75706 Butt weld	BW ends	75725 Butt weld	BW ends
ANSI 900 lbs	All sizes	ANSI 4500 lbs	All sizes
75809 Raised face	RF ends	75845 Raised face	RF ends
75709 Butt weld	BW ends	75745 Butt weld	BW ends
ANSI 1500 lbs	All sizes		
75815 Raised face	RF ends		
75715 Butt weld	BW ends		

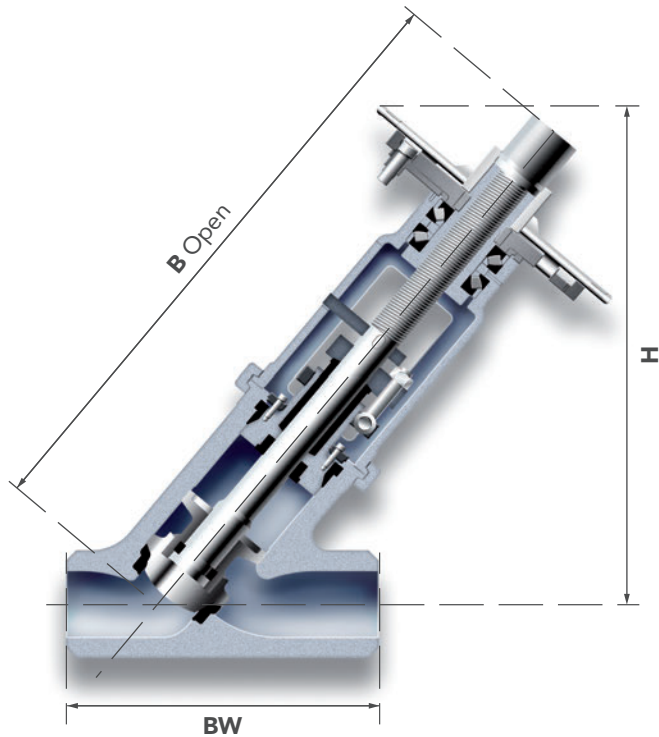

dimensions & weights chart

asme class

1500

SIZE	2 1/2"	3"	4"	6"	8"	10"	12"	14"	16"
BW	454	470	546	704.8	831.8	990.6	1130.3	1257.3	1409
B	532	532	858	1375	1480	1984	2200	2567	3250
H	510	510	709	1200	1023	1652	1780	2136	2650
WEIGHT (BW)	153	153	258	782	1275	1828	2560	3900	4590

2500

SIZE	2 1/2"	3"	4"	6"	8"	10"	12"	14"	16"
BW	508	508	673	914.4	1022.3	1270	1422.4	1574	1778
B	844	844	863	1327	1660	1930	2320	2780	3370
H	759	770	795	1085	1320	1770	1840	2110	2760
WEIGHT (BW)	336	336	458	1496	1618	2600	2703	4250	4800

All dimensions are shown in millimeters and weights in Kg.
 Operation: Impact wheel is recommended for valves up to 4" and Gear actuator for ≥6".

