

- Design:** ASME B16.34, BS-1873
- Sizes:** 2" - 48" (other sizes under request)
- ANSI Class:** 600 - 4500
- Face to Face:** ASME B16.10
- Flanged Ends:** From 2" to 24" as per ASME B16.5; above 24" as per ASME B16.47 or MSS-SP-44. Others upon request
- Butt Weld Ends:** ASME B16.25
- Test:** ASME B16.34, API 598, BS EN 12266-2 (BS 6755), ISO 5208. Others under request
- Construction/Features:**
- Parabolic, needle or ball type disc. Plug disc also available (see Code 95)
 - Allows installation in any position
 - Positive shut-off
 - Guided disc
 - Stellite disc, seat and backseat
 - Welded or integral seat and/or backseat construction
 - Streamlined body flow areas
 - Stem guide collar to prevent stem rotation
 - Pressure seal design with clamp, easy to disassemble
- Accessories:** Bypass, overpressure protection device, handwheel with chain, balance hole, lantern ring, belows seal, limit micro switches, spring loading packing
- Materials:** A216-WCB / WCC, A352-LCB, A217-WC6, A217-WC9, A217-C5, A217-C12, A217-C12A, A351-CF8, A351-CF3, A351-CF8M, A351-CF3M, A351-CF8C, Alloy 20, Duplex, Super Duplex, Incoloy, Monel, Inconel, Titanium
- Trim:** F6, 304, 310, Hard 410, 410 Full Hard faced, 410 and Ni-Cu, 410 and Hard faced, Monel, 316, Monel and Hard faced, 316 and Hard faced, Alloy 20, Alloy 20 & Hard faced, 304 Full Hard faced, 316 Full Hard faced, 347 Full Hard faced, Alloy 20 Full Hard faced, Alloy 625

Other trim and materials under request

Babcock Figure

ANSI 600 lbs	All sizes	ANSI 2500 lbs	All sizes
96806 Raised face	RF ends	96825 Raised face	RF ends
96706 Butt weld	BW ends	96725 Butt weld	BW ends
ANSI 900 lbs	All sizes	ANSI 4500 lbs	All sizes
96809 Raised face	RF ends	96845 Raised face	RF ends
96709 Butt weld	BW ends	96745 Butt weld	BW ends
ANSI 1500 lbs	All sizes		
96815 Raised face	RF ends		
96715 Butt weld	BW ends		

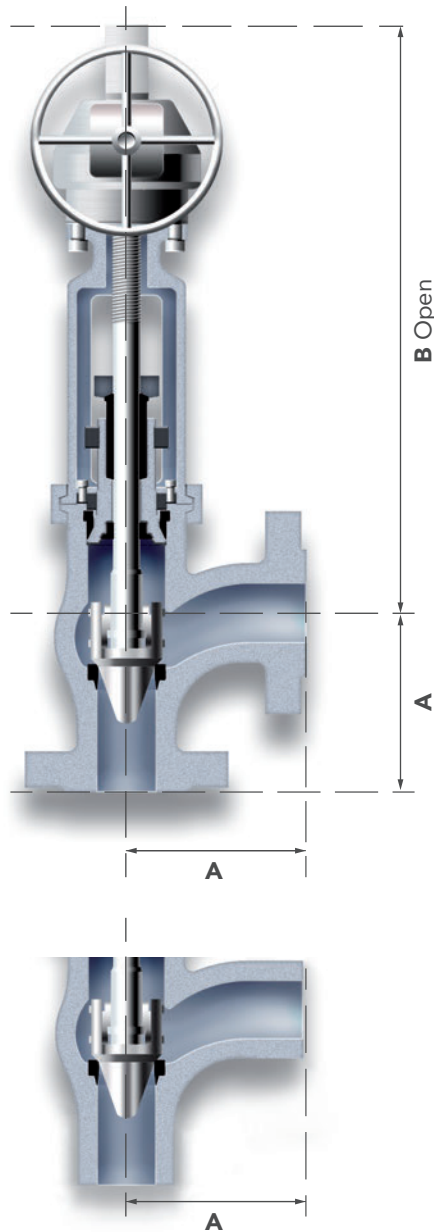

dimensions & weights chart

asme class
1500
2500

SIZE	2"	2½"	3"	4"	6"	8"	10"	12"	14"	16"
A	184	210	235	273	353	416	495	565	629	660
B	495	561	600	930	1375	1460	1750	2025	2225	2950
WEIGHT (BW)	82	95	95	160	483	790	1080	1236	1765	2285
SIZE	2"	2½"	3"	4"	6"	8"	10"	12"	14"	16"
A	226	254	289	337	457	511	635	711	787	830
B	645	688	673	800	1244	1540	1870	2135	2350	3080
WEIGHT (BW)	166	202	202	275	924	1640	3020	3780	4320	6380

All dimensions are shown in millimeters and weights in Kg.
 Operation: Impactor Wheel for valves $\leq 4"$.
 Gear actuator for valves $\geq 6"$.